

**Magnequench**<sup>®</sup>  
A Division of Neo Material Technologies Inc.  
*Leading Magnet Innovation*<sup>™</sup>

Introducing  
Anisotropic Powder

**MQA**

Sept 2009

2009

# Market Need

- Motors are being designed for reduced size, lighter weight, and higher efficiency
- Some application examples are:
  - Automotive accessory motors
    - Seat motors
    - Window lift motors
    - Others
  - Home appliances
    - Washing machines
    - Compressors for refrigerators
  - Cordless power tools

***Magnequench***

# Solution: MQA

- New anisotropic powder grades will have the following characteristics
  - Substantially higher energy product and remanence than isotropic powders
  - Higher  $H_{ci}$  and therefore higher resistance to demagnetization
- MQA grades will provide more flexibility in motor designs of the future
- Improved motor efficiency
- Further weight and size reduction of motor

***Magnequench***

# Basic MQA Manufacturing Process

**MQU**

**MQ2  
(Hot Press)**

MQ2 Hot Pressed Magnet Process

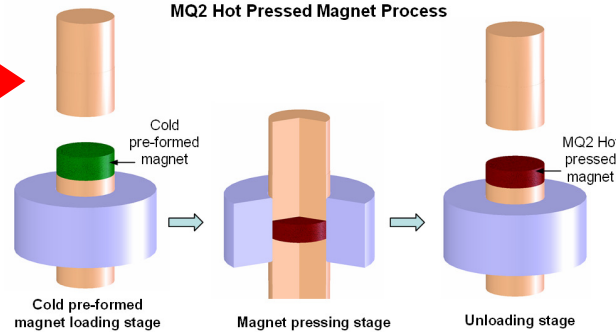

**MQ3  
(Crystallographic alignment)**

MQ3 Hot Pressed Magnet Process

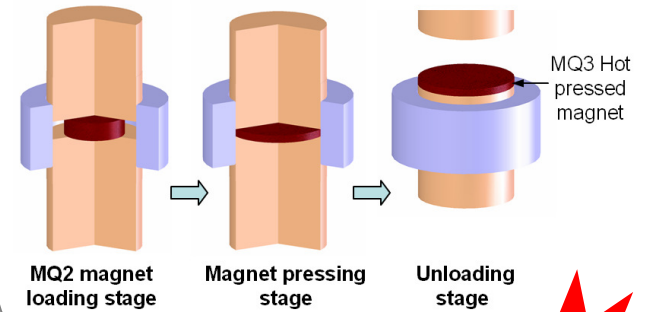

**Coating**

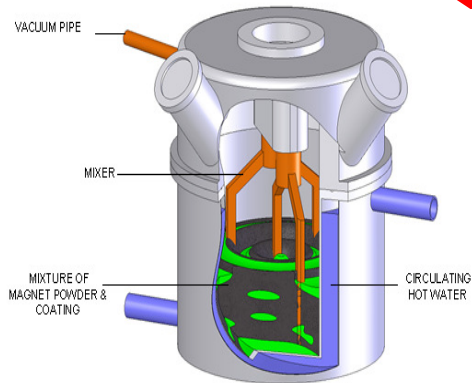

**Fine Crush**

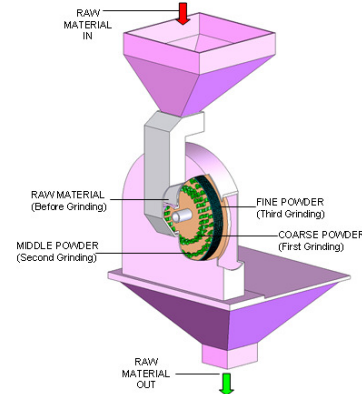

**Jaw Crush**

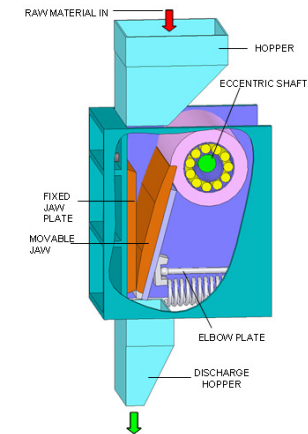

**Magnequench**

# Target Grades and Properties

- Targeted grades are as follows:
  - MQA-37-11
  - MQA-38-14
  - MQA-37-16
  - MQA-36-18
- Samples are available
  - Powder quantities produced and order in which they are produced will subject to market feedback

\*Magnetic properties and resulting names are for reference only. Actual properties and names are subject to change

***Magnequench***

# Target Products

		MQA-37-11	MQA-38-14	MQA-37-16	MQA-36-18
<b>Part Number</b>		20094-065	20077-065	20096-065	20095-065
<b>B<sub>r</sub></b>	<b>mT</b>	1300	1310	1290	1240
	<b>kG</b>	13.0	13.1	12.9	12.4
<b>(BH)<sub>max</sub></b>	<b>kJ/m<sup>3</sup></b>	290	300	295	285
	<b>MGOe</b>	36.5	38.0	37.0	36.0
<b>H<sub>ci</sub></b>	<b>kA/m</b>	840	1120	1270	1430
	<b>kOe</b>	10.5	14.0	16.0	18.0
<b>&gt; 100Mesh</b>		<1%			
<b>&gt; 140Mesh</b>		<50%			
<b>&lt; 270Mesh</b>		<35%			
					
					

**Magnequench**

# Powder Curves

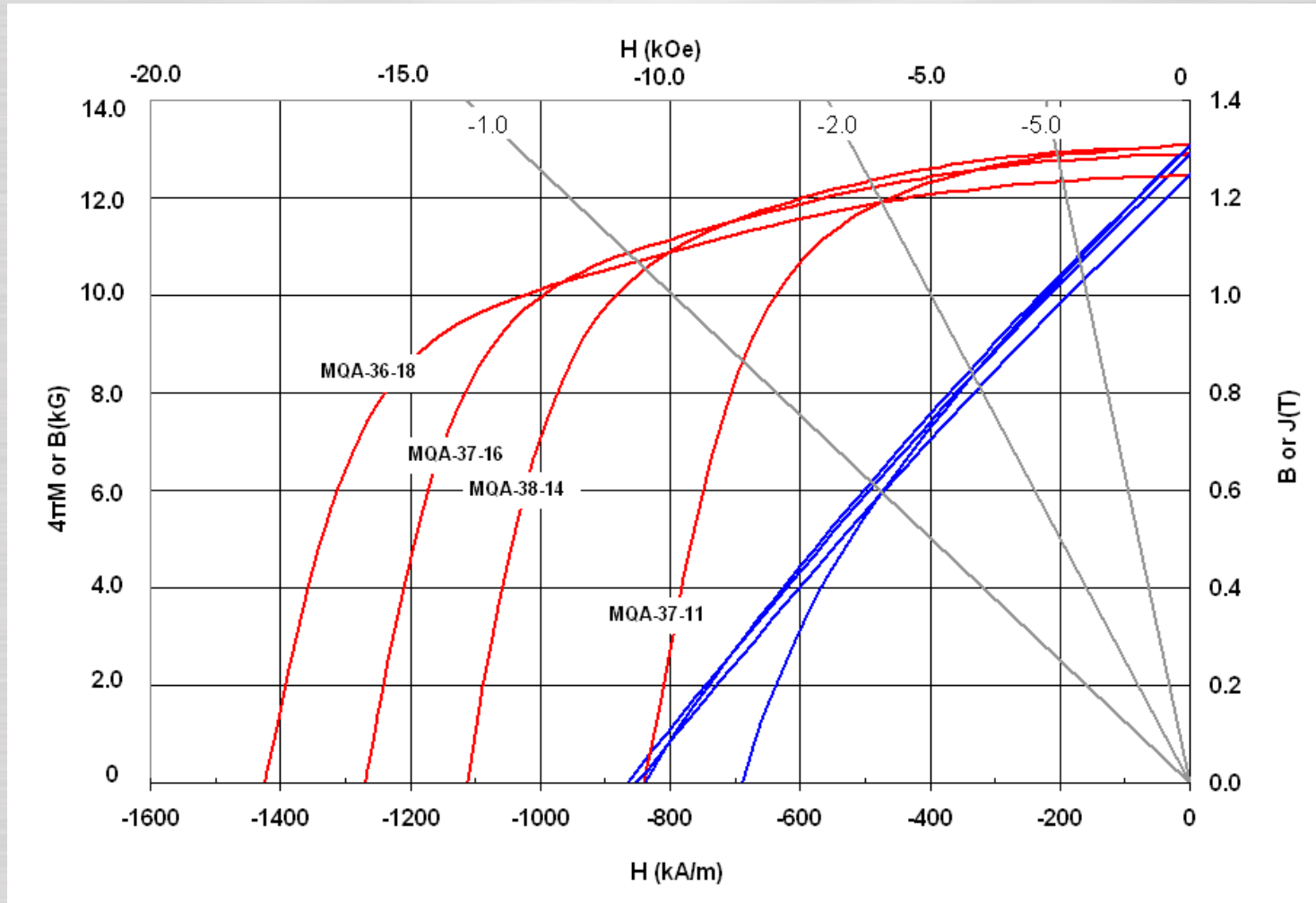

**Magnequench**

# Powder Properties

- Detailed technical data is being generated for the target MQA grades
- Data include:
  - Magnetic characteristics
  - Demagnetization curves
  - Physical characteristics
    - Sieve screen analysis of different mesh sizes
    - Density
  - Orientation field
  - Magnetizing field

***Magnequench***

# Magnet Properties

- Compression molded magnet samples are being fabricated at Magnequench Technology Center (MQT)
- Injection molded magnets were fabricated at Toda Magnequench Magnetic Material (Tianjin) Co. Ltd (TMT)
  - For internal evaluation purposes only
    - No plans to distribute magnet samples

***Magnequench***

# Compression Molded Magnet Samples for Aging data

- Shape of magnet = Cube ( $1\text{cm}^3$ )
- Load line =  $PC=3.1$
- Type and amount of epoxy = Dry blend epoxy, 2% wt
- Compression pressure =  $7.5\text{ T/cm}^2$
- Pressing temperature = Room temperature
- Orienting field =  $\sim 17\text{ kOe}$
- Cure condition =  $180^\circ\text{C}$  for 30mins

# Magnet Aging (MQA-37-11)

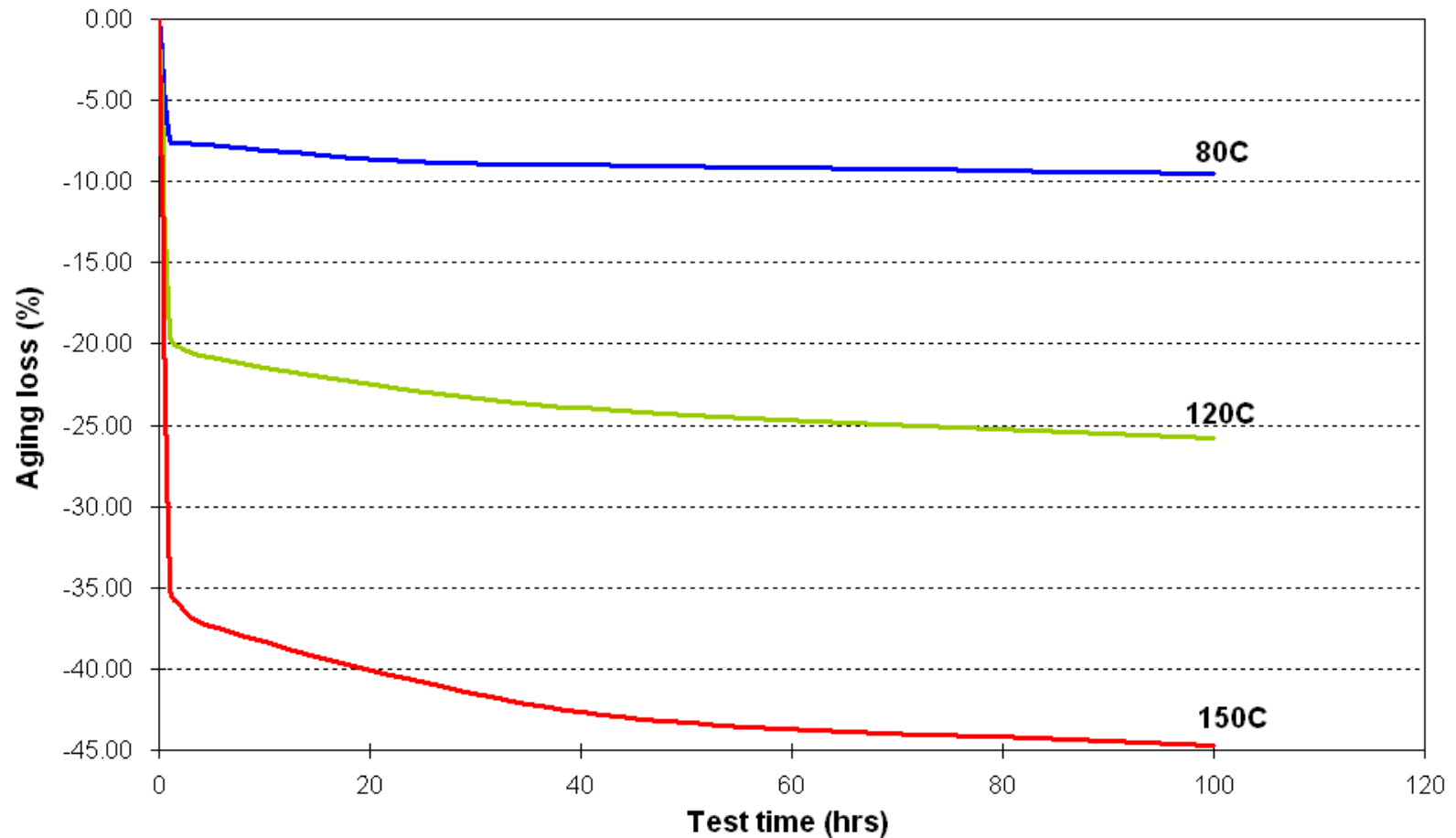

**Magnequench**

# Magnet Aging (MQA-38-14)

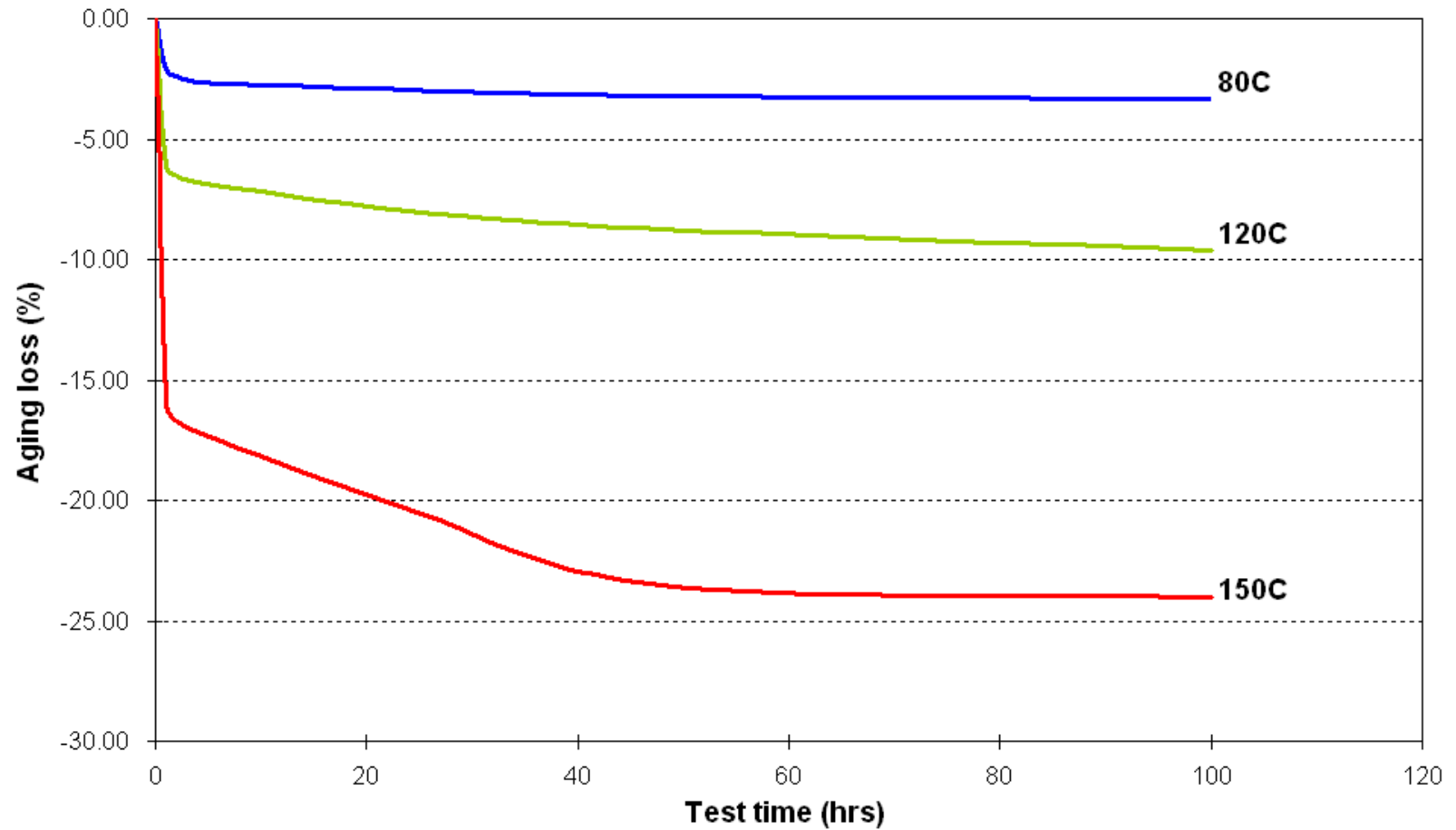

**Magnequench**

# Magnet Aging (MQA-37-16)

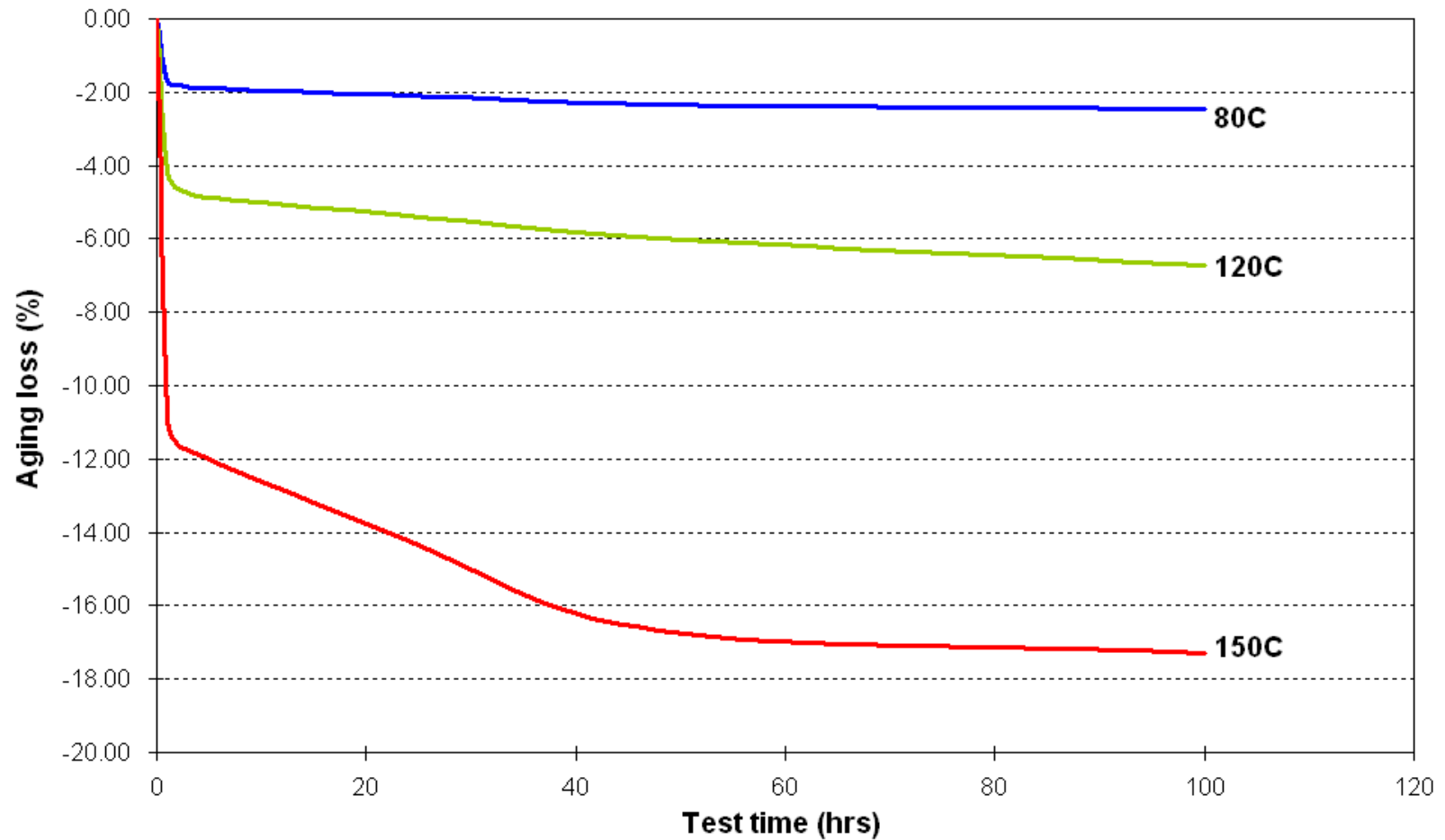

**Magnequench**

# Magnet Aging (MQA-36-18)

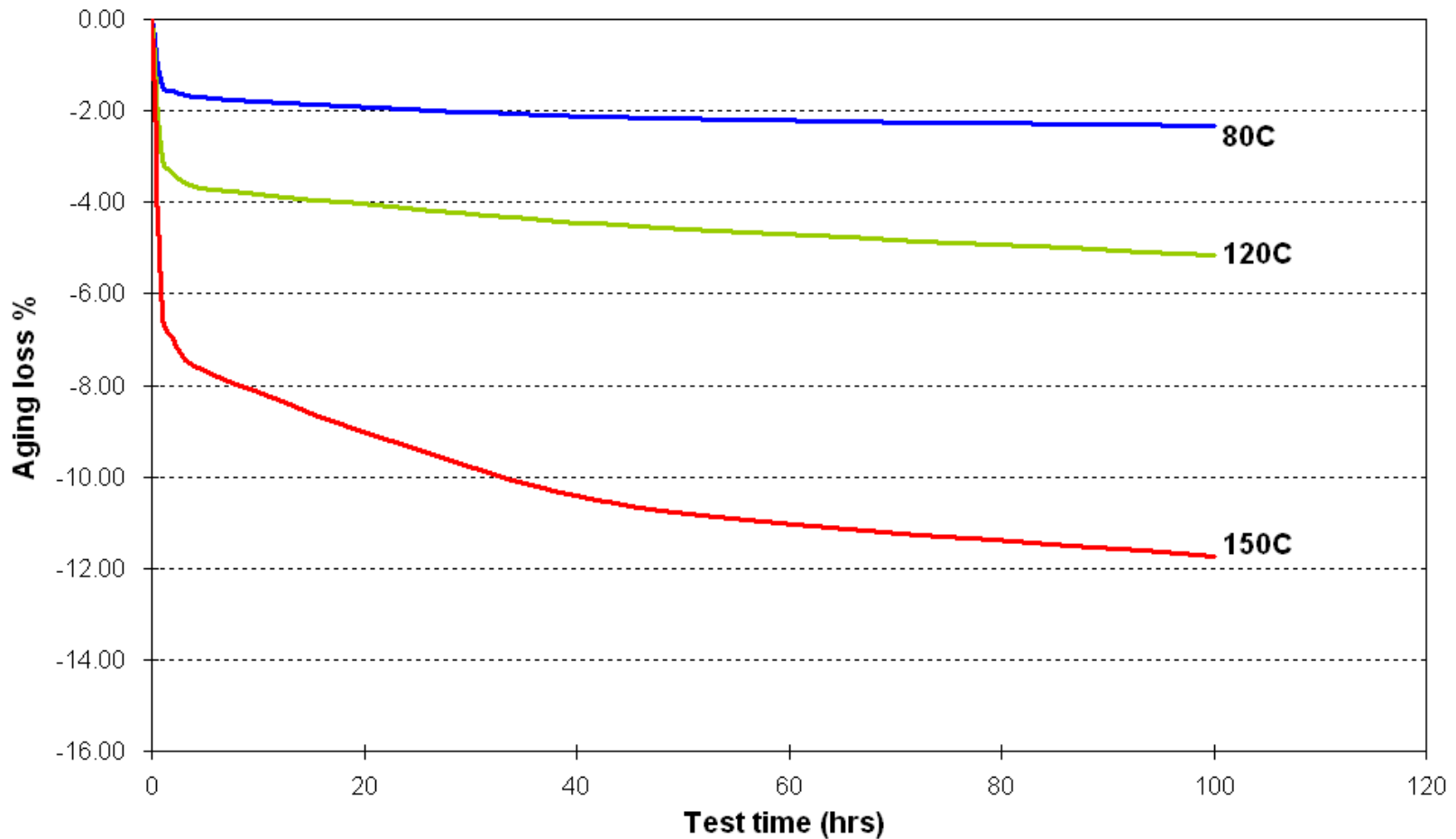

**Magnequench**

# Estimated Magnet Curve (MQA-37-11)

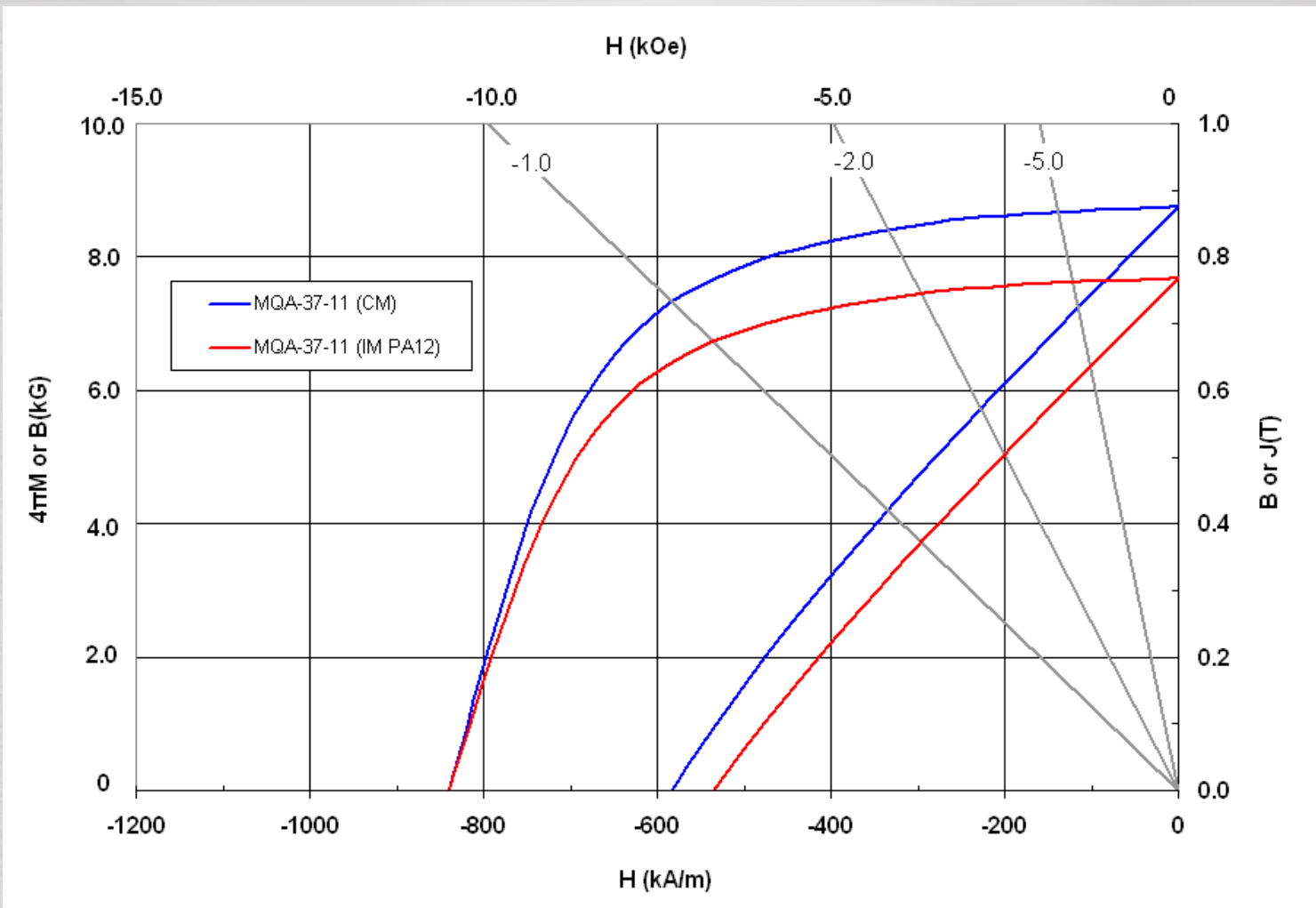

**Magnequench**

# Estimated Magnet Curve (MQA-38-14)

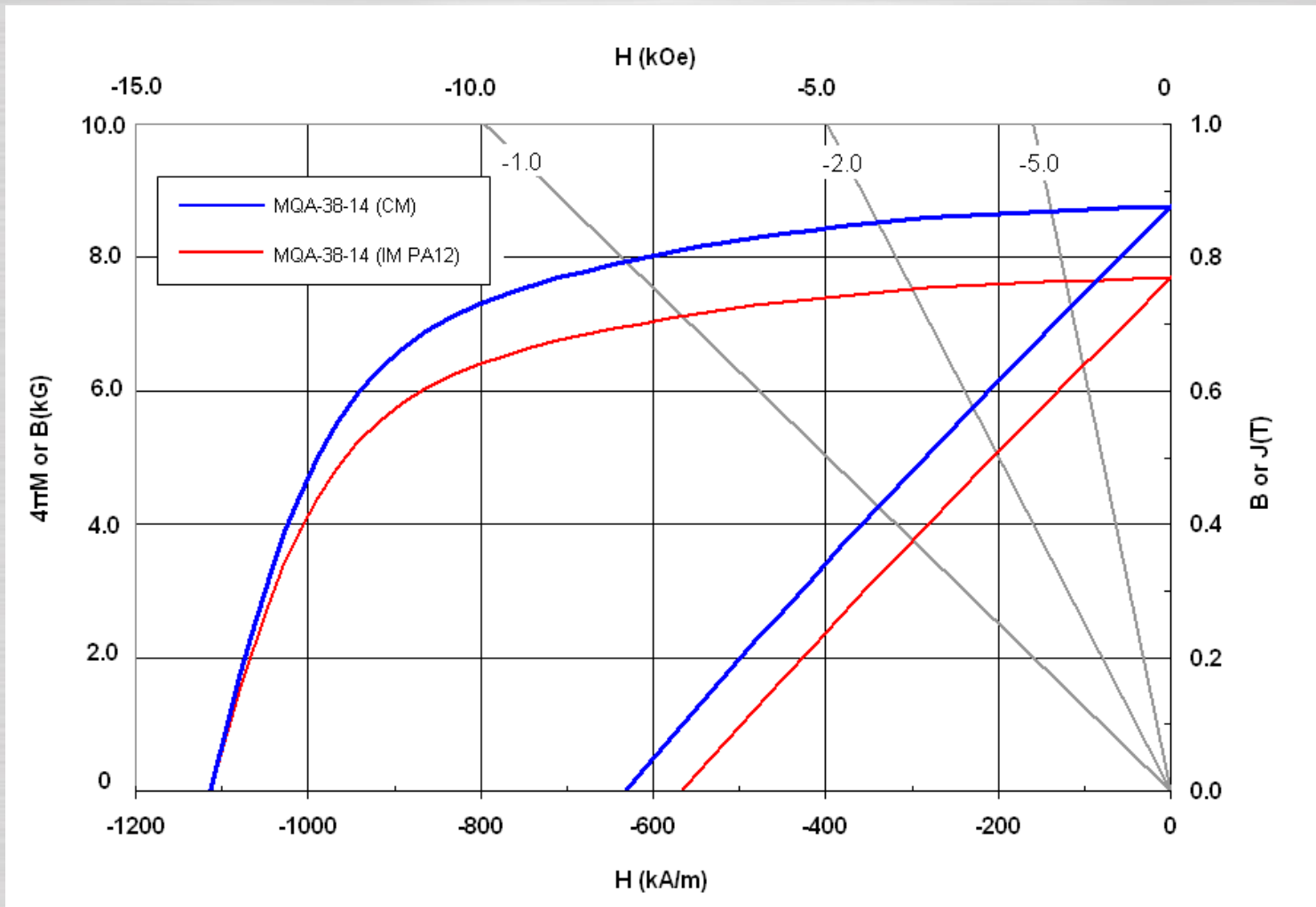

**Magnequench**

# Estimated Magnet Curve (MQA-37-16)

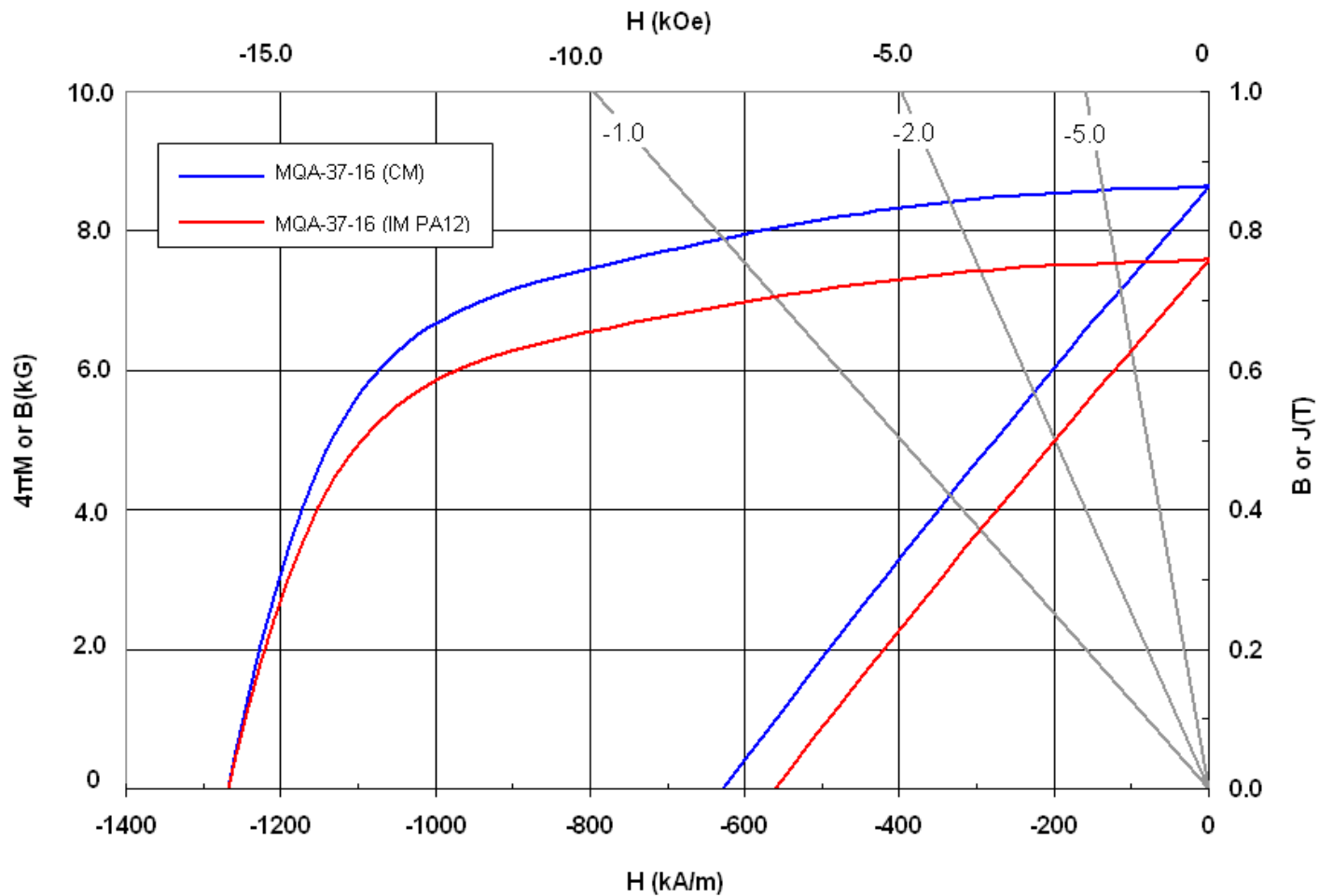

**Magnequench**

# Estimated Magnet Curve (MQA-36-18)

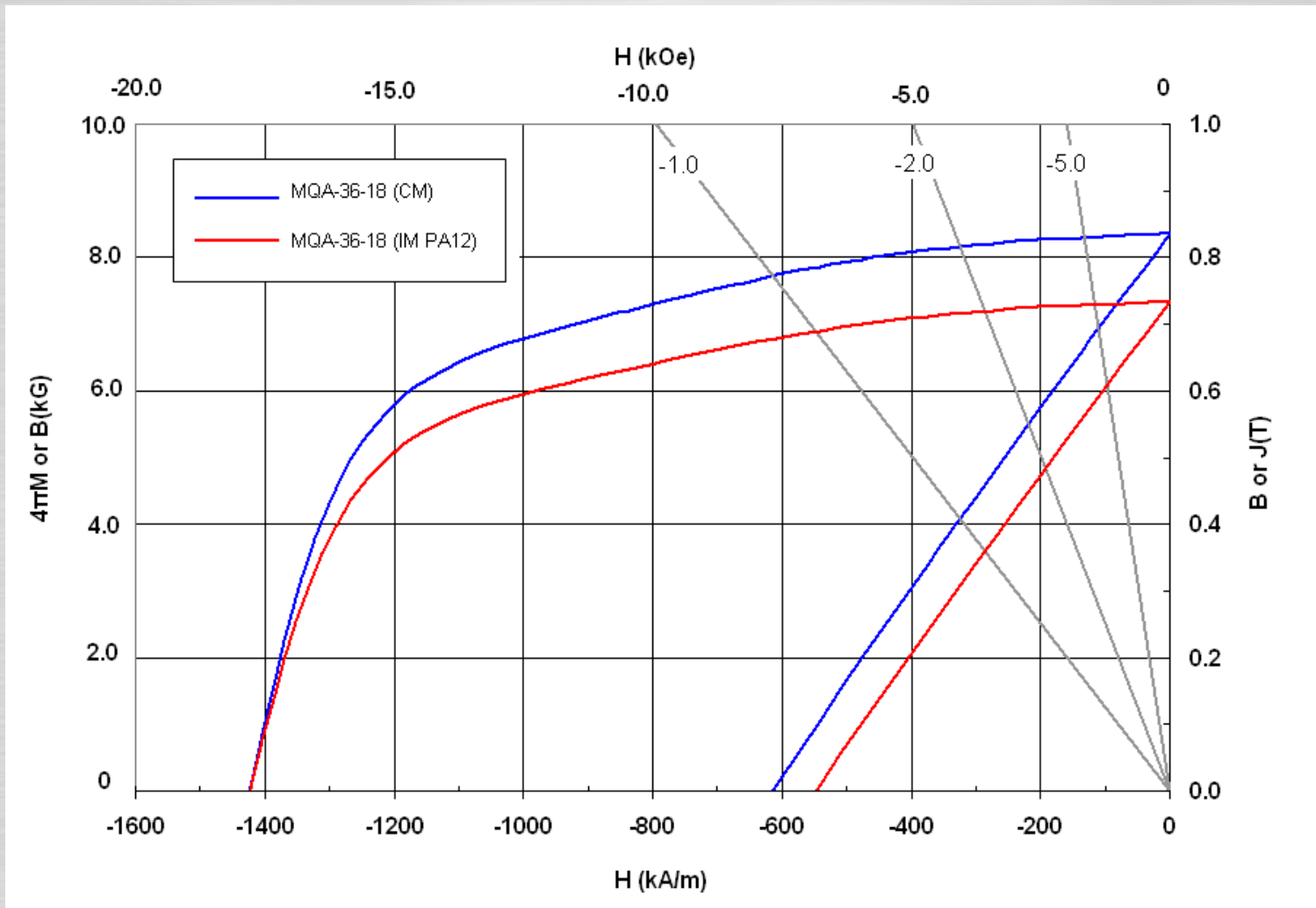

**Magnequench**

# Past Developments

- PSD optimization
  - Improve magnet density and particle alignment
- Aging loss improvements
  - Improved processes
  - Proprietary anti-aging powder coatings

***Magnequench***

# Narrower PSD

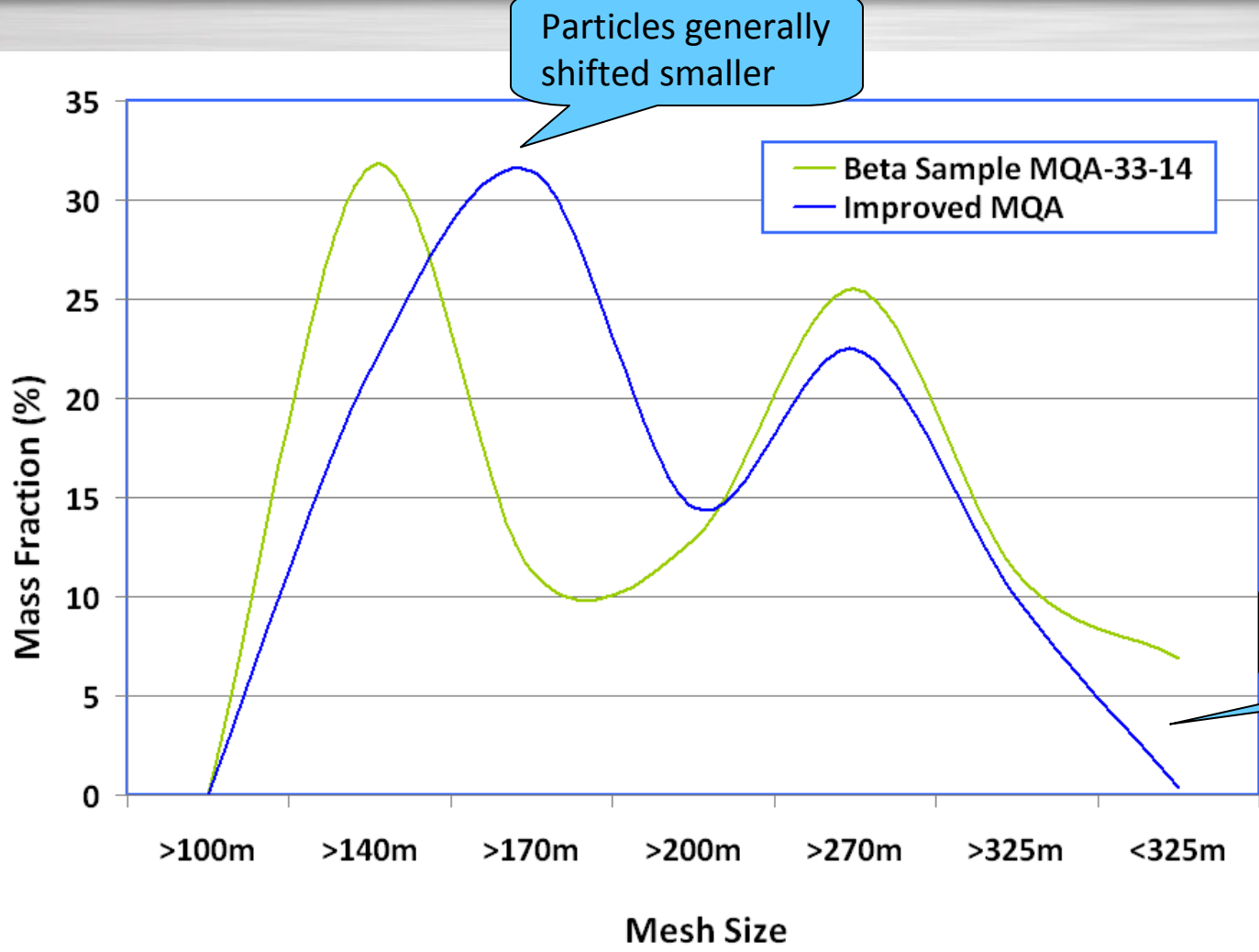

# SEM Pictures



Signal A = MPSE EHT = 5.00 kV 100µm Date :15 Jul 2009  
Mag = 150 X WD = 8 mm Vacuum Mode = High Vacuum Time :14:41:57

MQA-37-11 @ 100µm



Signal A = MPSE EHT = 5.00 kV 100µm Date :15 Jul 2009  
Mag = 150 X WD = 8 mm Vacuum Mode = High Vacuum Time :14:53:01

MQA-38-14 @ 100µm

# Future Developments

- Customer feedback is important
- We are more than willing to explore other new possible product grades.
  - Please let us know if you have any other desired magnetic or mechanical properties
- Continued PSD studies and modification

***Magnequench***

# MQA Summary

- Highest performing range of Magnequench powders
  - Substantially higher  $(BH)_{\max}$  and  $B_r$
- Competitive with existing powders for anisotropic bonded magnets
- Exploring multiple grades based on customer feedback
- Contact your sales representative for samples and additional information

This powder, the products that are made there from, and its manufacturing processes are subject to one or more of the following United States Patents: US 5,093,076, US 5,172,751, US 5,174,362, US 5,411,608, US 5,645,651

**Magnequench**



# Other Reference Data

# Orientation Field

## (Beta Sample MQA-33-14)

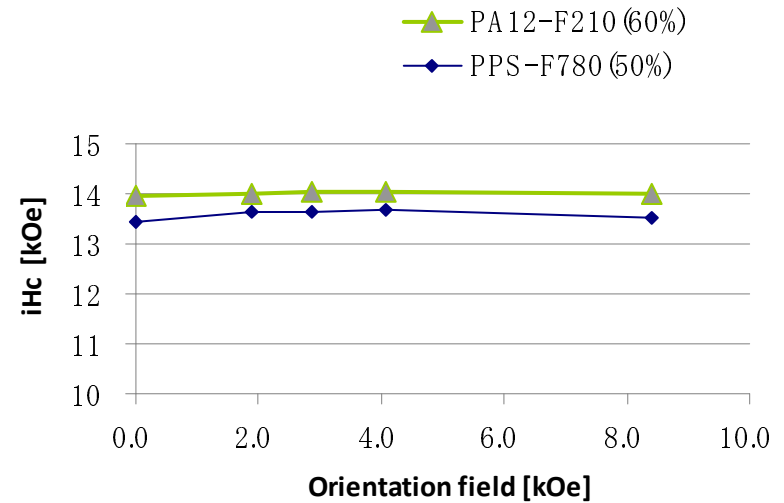
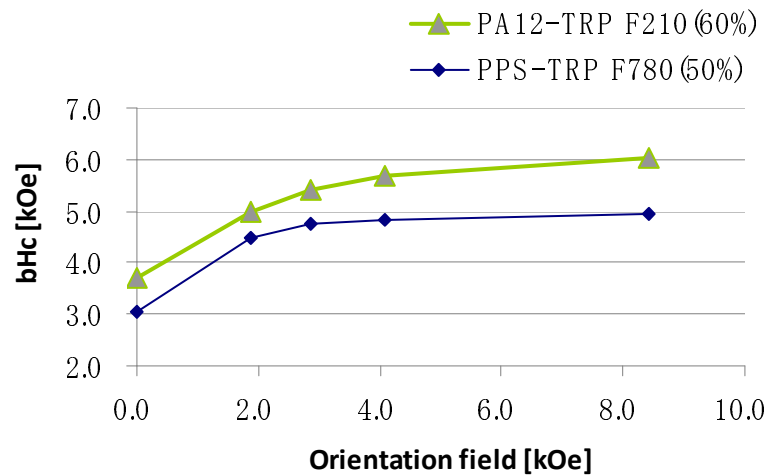
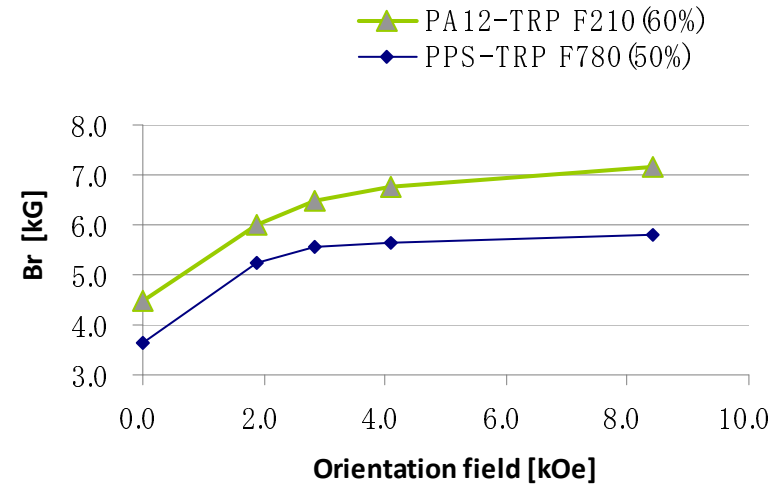
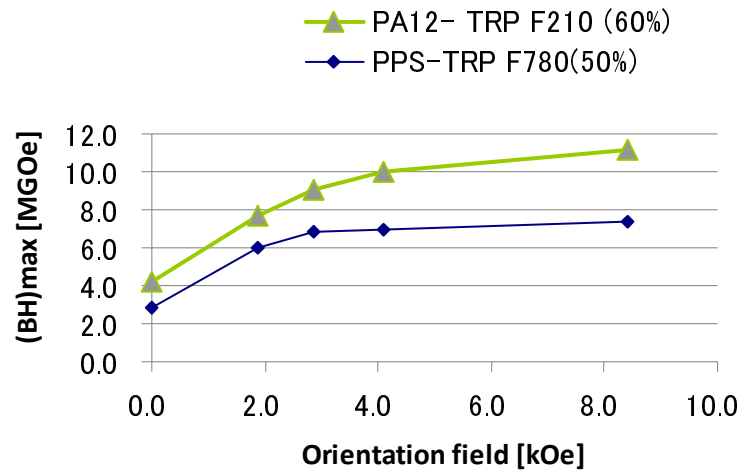

\*Data provided by TMT

**Magnequench**

# IM Results

(Beta Sample MQA-33-14)

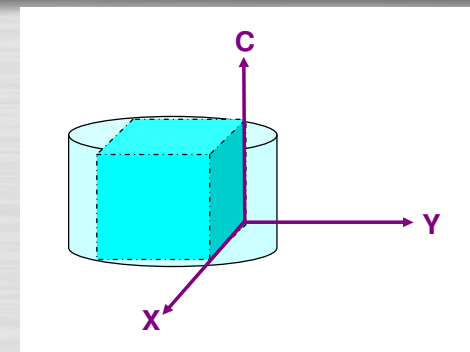

Hysteresis (3-axis) -TRP F210 60 vol.%

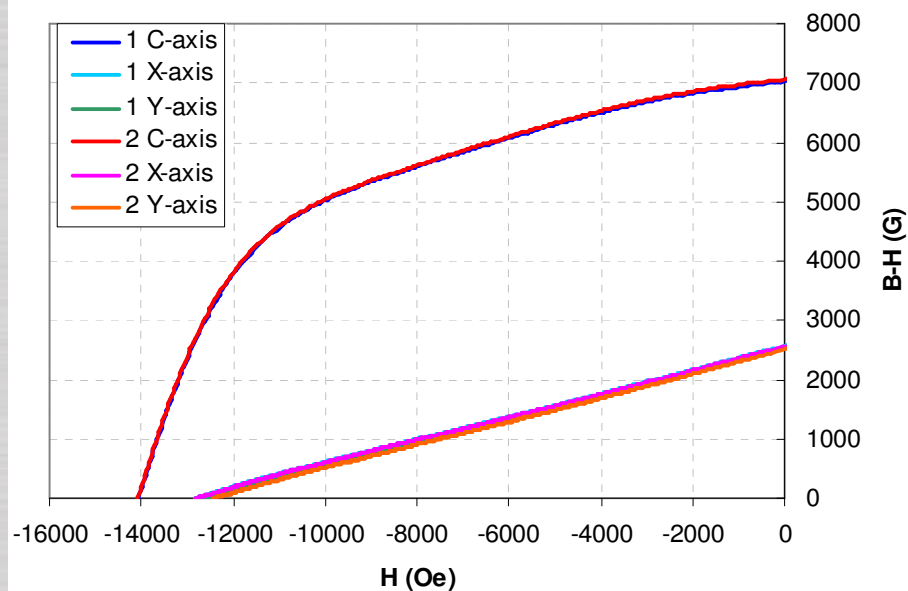

Hysteresis (3-axis) - TRP F780 50 vol.%

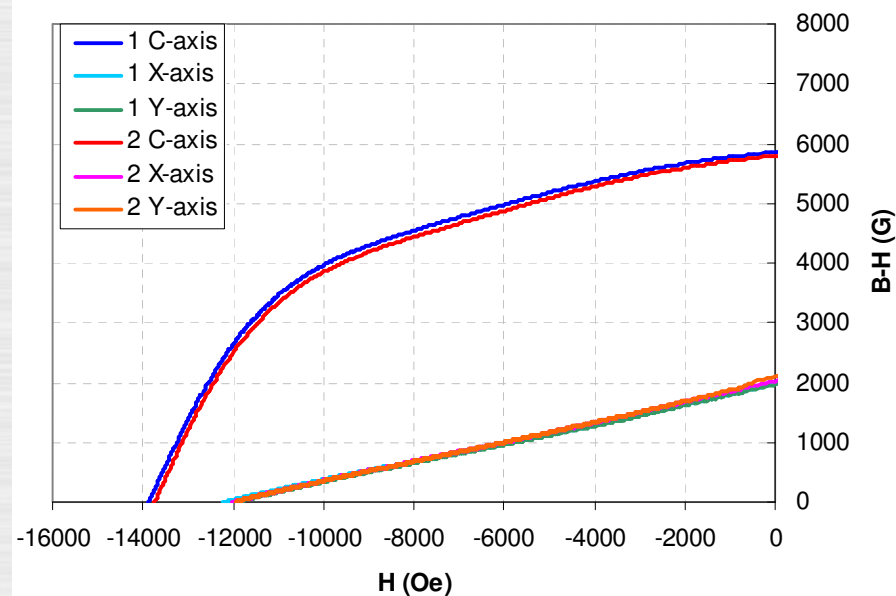

\*Data provided by TMT

**Magnequench**

# Magnet Aging

(Beta Sample MQA-33-14)

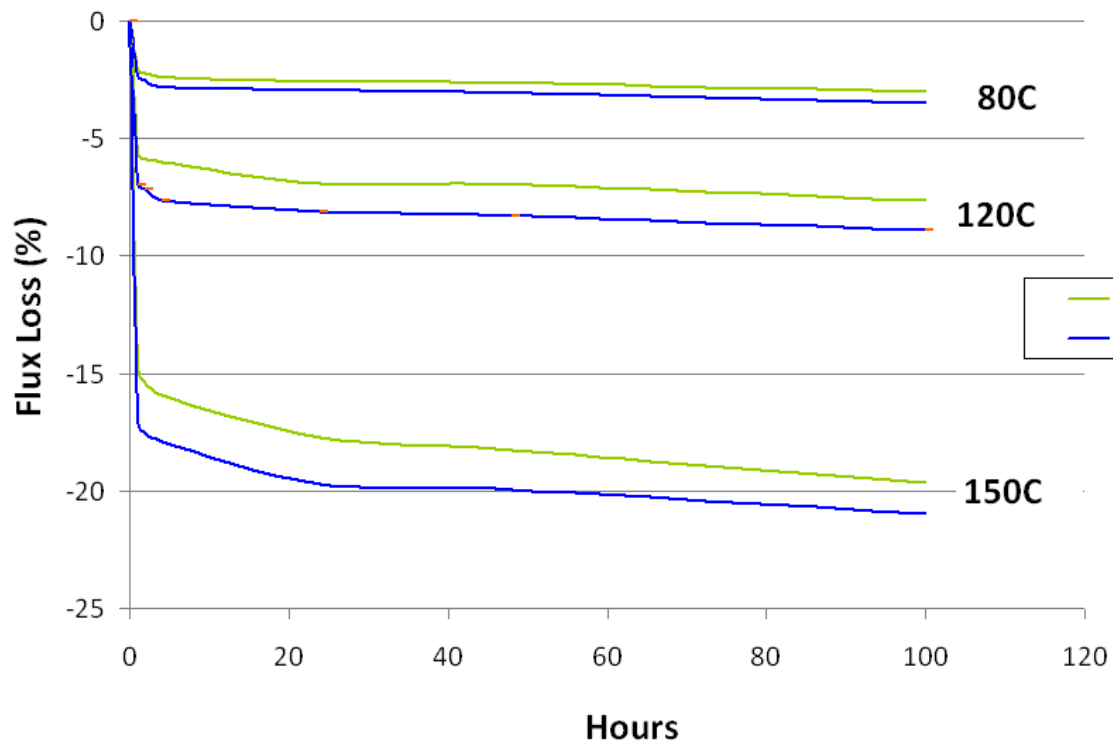

- Initial losses are sensitive to temperature
- PA12 is better than PPS
- Aging is unaffected by loading amount

\*Data provided by TMT

**Magnequench**

# Magnetization

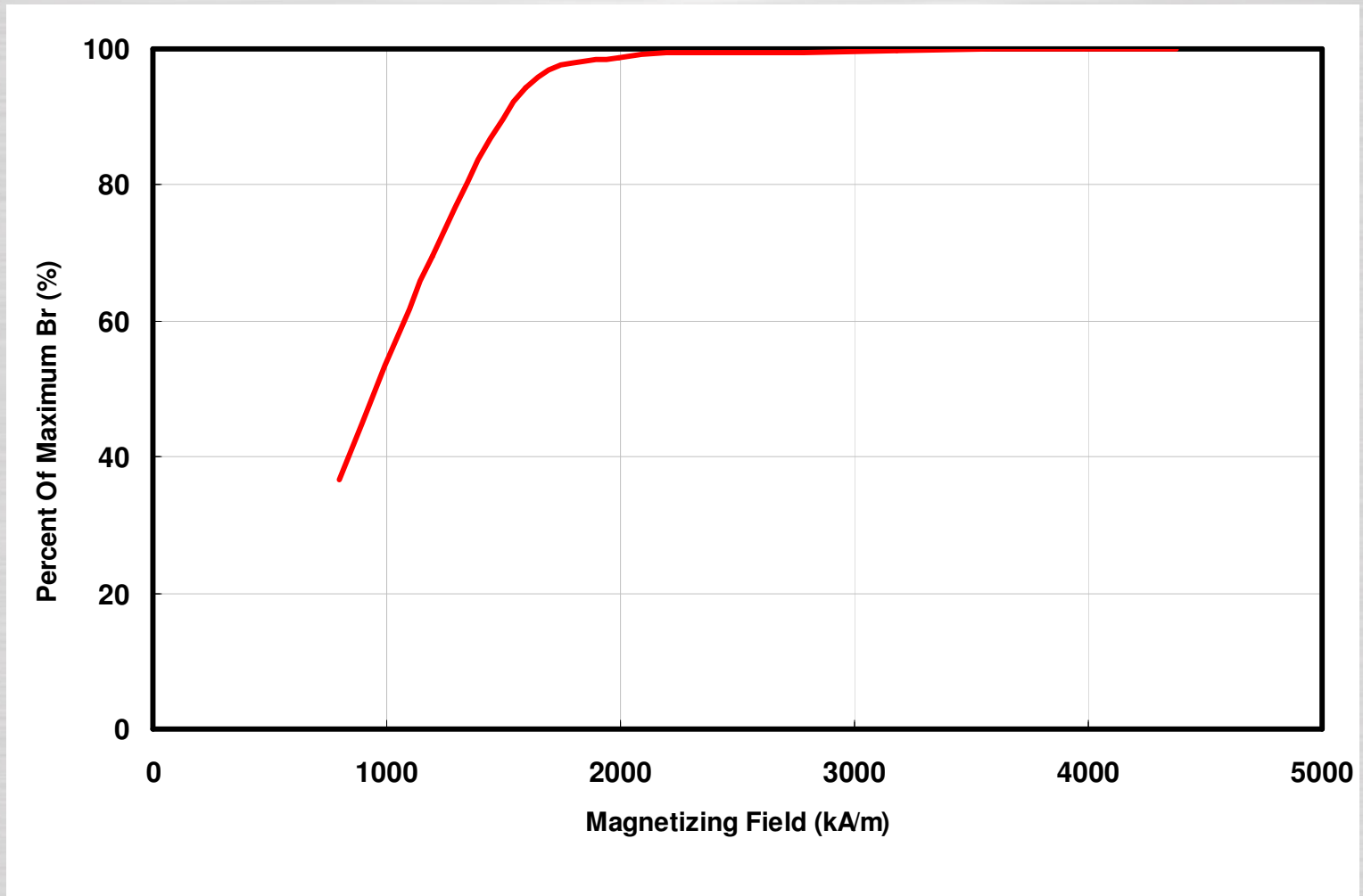

**Magnequench**